

# Tests on concrete

## 1. The Slump Test

### Materials and tools

- A sample of freshly mixed concrete (about half a wheelbarrow full)
- A wheelbarrow and shovel
- A flat steel plate about 600 x 600 mm by 3 mm thick
- A metric rule or tape measure
- A scoop
- A steel tamping rod, 16 mm in diameter by 600 mm long that has at least one end rounded
- A standard slump mould (see Figure 1). The footplates should be positioned 5 mm above the base of the cone.

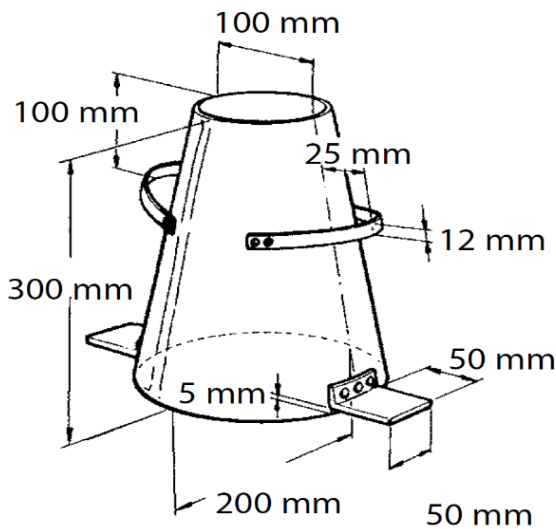

Figure 1

### How to measure the slump

1. Mix the concrete in the wheelbarrow.
2. Wipe all the tools including the mould and base plate with a damp cloth.
3. Put the steel plate down on a level place so that it is firm, and then put the slump mould on it with the narrow end at the top. Stand on the *footpieces*.
4. Fill the slump mould in three layers of about equal depth. Tamp through each layer 25 times with the rounded end of the tamping rod.
5. The last layer should more than fill the mould. After tamping the last layer, strike off the excess concrete, using a sawing and rolling motion of the tamping rod, so that the mould is completely filled and level.

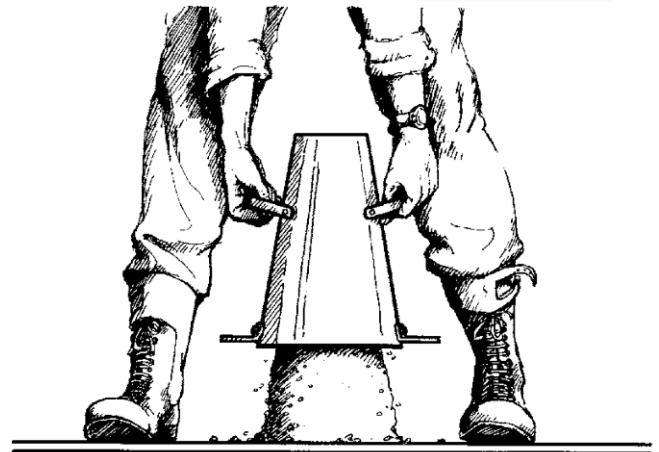

Figure 2

6. Hold the mould by the handles to keep it steady while you step off the foot pieces.
7. Slowly lift the slump mould straight up and off (See Figure 2).
8. Turn the slump mould upside down and place it on the plate, next to the concrete.

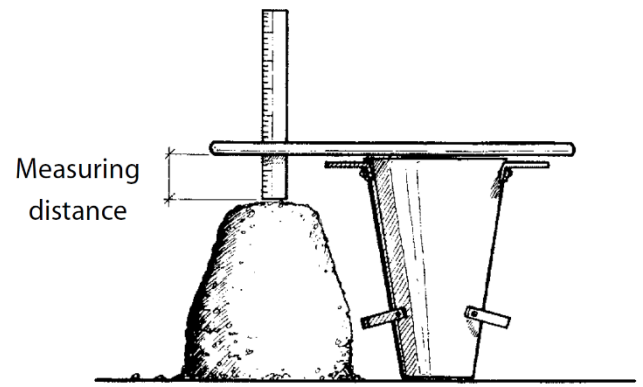

Figure 3

9. Rest the tamping rod on top of the slump mould so that one end is above the concrete.
10. Carefully measure the distance between the bottom of the tamping rod and the highest point of the concrete to the nearest 5 mm (see Figure 3).
11. If you don't get a true slump (see Figure 4), repeat the test. If the slump is still not normal, ask for advice.

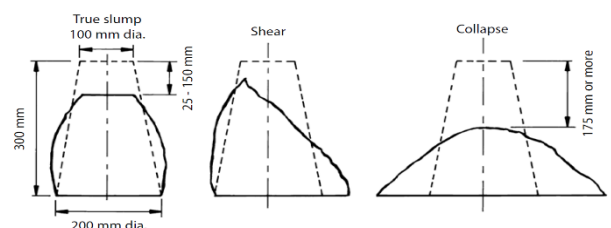

Figure 4

## 2. How to make 150-mm cubes

Note – Three cubes are needed for each test. If they are to be tested at 7 days and at 28 days, you will need six cubes—three for each test.

### Material and tools

- A sample of the concrete (about half a wheelbarrow full)
- A wheelbarrow and a shovel
- A scoop
- Three standard moulds for each test
- A steel tamping rod, 600 mm long with a diameter of 16 mm that has at least one end rounded
- A steel float
- Pieces of writing paper (absorbent paper) for labels
- A ballpoint pen or, preferably, a soft pencil
- Mould release oil
- Grease

### How to make the cubes

1. Check that:
  - moulds are clean and do not have dust or dirt on them,
  - the joint faces have been greased,
  - they are assembled in the right way,
  - the bolts are tight.
2. Smear release oil very thinly on the inside faces of the moulds.
3. Place the moulds on a firm, level surface.
4. Mix the concrete well in the wheelbarrow.
5. Fill the moulds with concrete in 50 mm layers.
6. Tamp each layer at least 45 times with the rounded end of the tamping rod to get the air bubbles out.
7. The tamping rod should not penetrate the previous layer by more than 10 mm's.
8. The last layer should more than fill the mould. After tamping the last layer, use the steel float to strike off the surface of the concrete so that it is level with the top of the mould.
9. Write the following on a label for each cube:
  - the company's name,
  - the contract number or the reference number,
  - the date when the cube is made.
10. Gently press the label onto the top of the cube.
11. Cover the cube with damp sacking followed by a sheet of plastic and store it in the shade, away from wind and where it will not be disturbed.
12. If the weather is cold, make and store the cubes indoors.

### The next day

1. Loosen all the bolts on the mould.
2. Gently loosen the sides of the mould and remove them.
3. It is a good idea to write the information on the label on the cube with a lumber crayon.
4. Put the cubes into water. The temperature of the water should be 22°C - 25°C.
5. Leave the cubes covered with water until they are taken to the testing laboratory.
6. Clean the moulds and assemble them again.

### References:

- SANS 5860:2006 Concrete tests – Dimensions, tolerances and uses of cast test specimens.
- SANS 5862 -1:2006 Concrete tests – Consistence of freshly mixed concrete – Slump test.
- SANS 5861 -2:2006 Concrete tests – Sampling of freshly mixed concrete.
- SANS 5861 -3:2006 Concrete tests – Making and curing of test specimens.
- SANS 5863:2006 Concrete tests – Compressive strength of hardened concrete.